

η and η' physics at BESIII

Shuangshi Fang
(for the BESIII Collaboration)

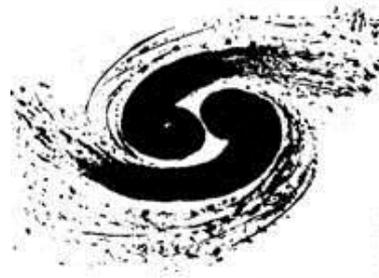

Institute of High Energy Physics

MesonNet meeting
June 17-19, 2013, Prague, CZE



OUTLINE

- Introduction
- η/η' events at BESIII
- Recent results
 - $\eta' \rightarrow \pi^+\pi^-\eta$
 - $\eta (\eta') \rightarrow \pi^+\pi^-, \pi^0\pi^0$
 - $\eta' \rightarrow \pi^+\pi^-\pi^0, \pi^0\pi^0\pi^0$
 - $\eta' \rightarrow \pi^+\pi^-e^+e^-, \pi^+\pi^-\mu^+\mu^-$
 - invisible & weak decays
- Summary & Perspective



Introduction

Phys. Rev. Lett. 7,421(1961)

Phys. Rev. Lett. 12,567(1964)

Discovered about 50 years ago

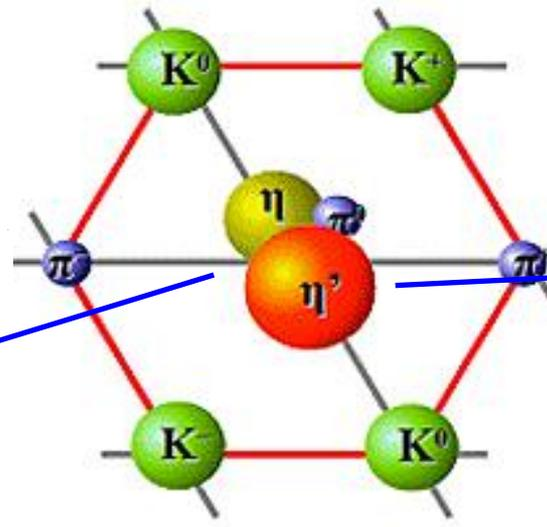
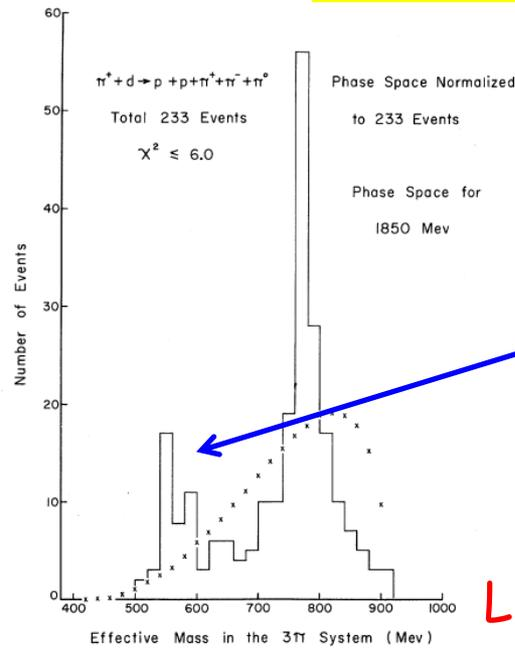

Lightest pseudoscalar nonet

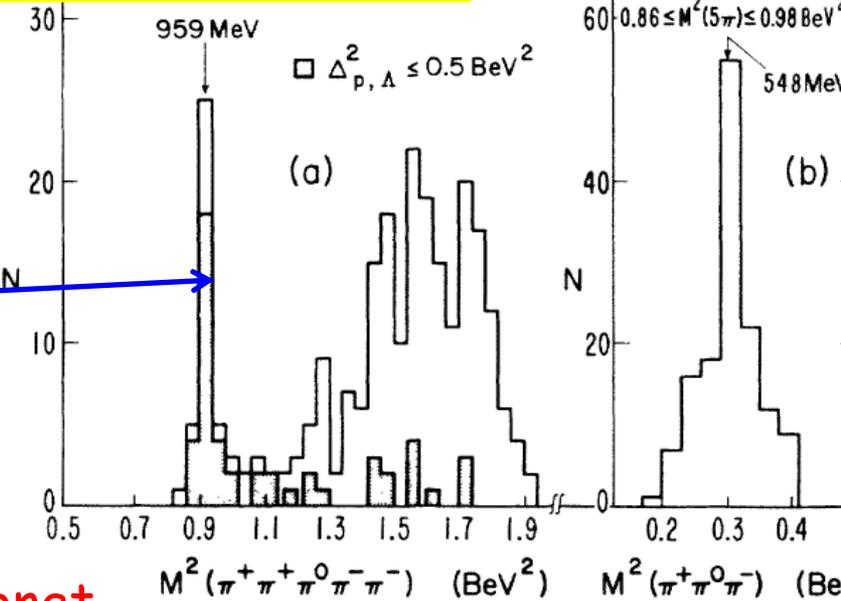

● Dominant decay modes were observed

$\eta \rightarrow 2\gamma$ 39.31%
 $\eta \rightarrow \pi^+\pi^-\pi^0$ 22.74%
 $\eta \rightarrow \pi^0\pi^0\pi^0$ 32.57%
 $\eta \rightarrow \gamma\pi^+\pi^-$ 4.60%

$\eta' \rightarrow \pi^+\pi^-\eta$ 44.6%
 $\eta' \rightarrow \gamma\rho(\gamma\pi^+\pi^-)$ 29.4%
 $\eta' \rightarrow \pi^0\pi^0\eta$ 20.7%
 $\eta' \rightarrow 2\gamma$ 3.02%
 $\eta' \rightarrow \gamma\omega$ 2.10%



Introdcution

- Still listed in many facilities' physics program (KLOE, WASA-at-COSY, CB at MAINZ, CLAS, GlueX, **BESIII**)
- **η/η' : a rich physics field**
 - Unique place to test fundamental symmetries in QCD at low energy
 - Probe physics beyond the Standard Model (SM)

$$\eta/\eta' \rightarrow 2\gamma$$

chiral anomaly

$$\eta/\eta' \rightarrow \pi^+\pi^-\pi^0$$

quark masses

$$\eta' \rightarrow \gamma\pi^+\pi^-$$

box anomaly

$$\eta/\eta' \rightarrow \pi\pi$$

CP violation

$$\eta/\eta' \rightarrow \mu^+\mu^-\pi^0, e^+e^-\pi^0$$

C violation

$$\eta/\eta' \rightarrow \mu e$$

LF violation

.....

Bird view of BEPCII

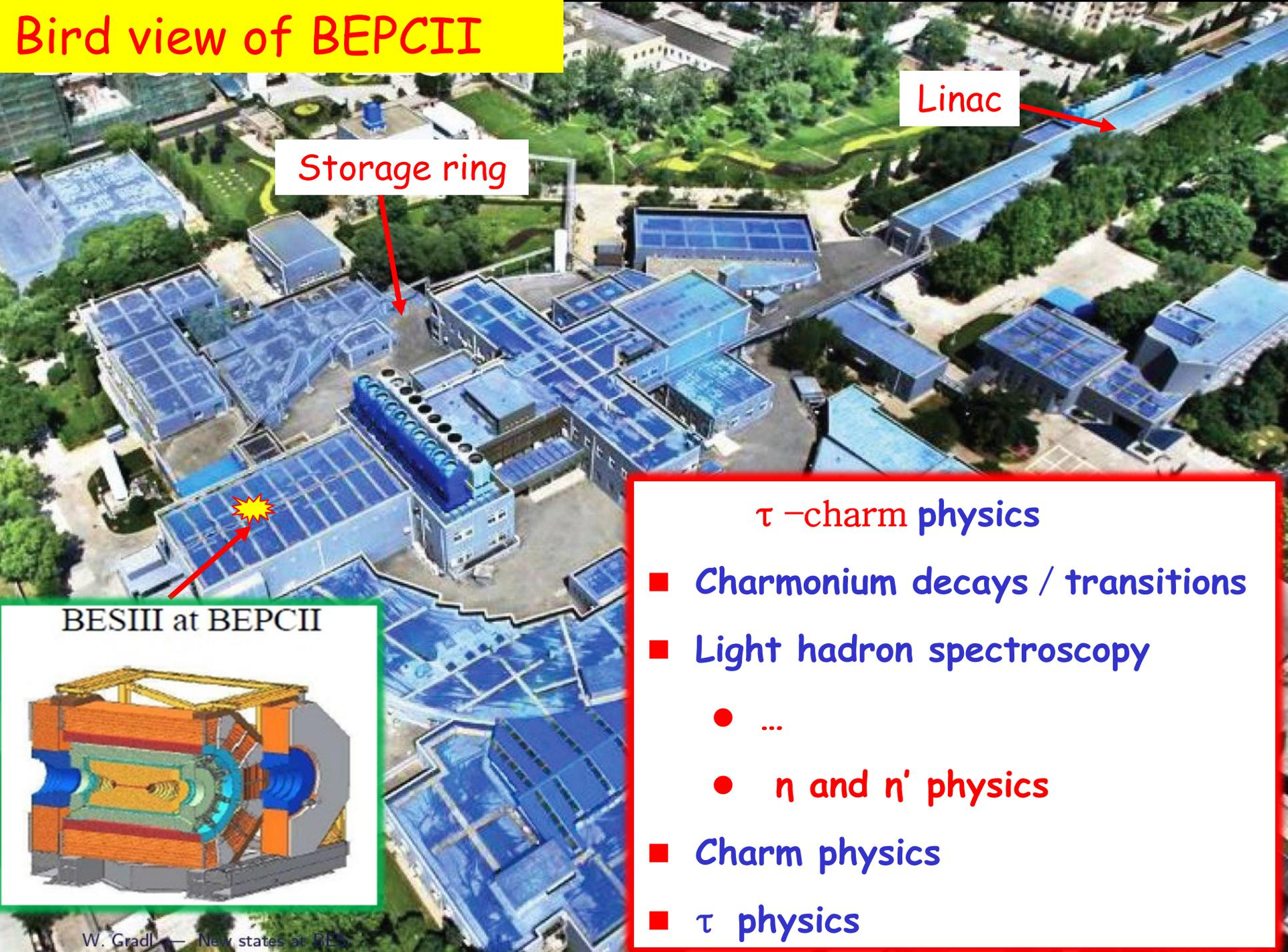

Storage ring

Linac



BESIII at BEPCII

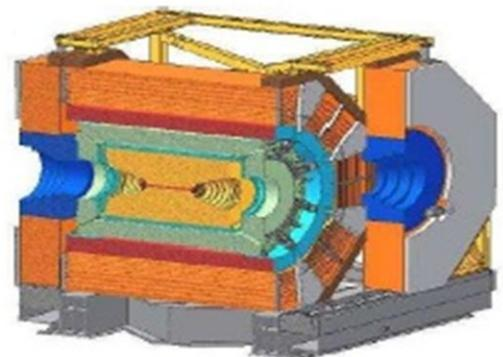

- τ -charm physics
 - Charmonium decays / transitions
 - Light hadron spectroscopy
 - ...
 - η and η' physics
 - Charm physics
 - τ physics

The BESIII Detector

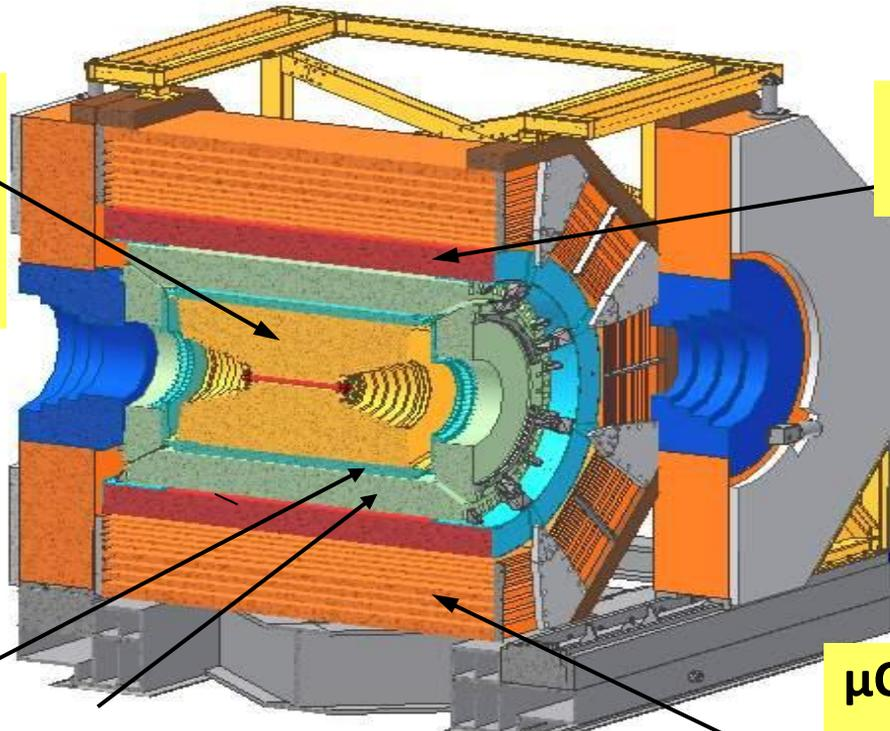

Drift Chamber (MDC)

$$\sigma_{P/P} (\%) = 0.5\% (1\text{GeV})$$

$$\sigma_{dE/dx} (\%) = 6\%$$

Super-conducting magnet (1.0 tesla)

Time Of Flight (TOF)

$$\sigma_T: 90 \text{ ps Barrel}$$

$$110 \text{ ps endcap}$$

EMC: (CsI)

$$\sigma_{E/\sqrt{E}} (\%) = 2.5\% (1 \text{ GeV})$$

$$\sigma_{z,\phi} (\text{cm}) = 0.5 - 0.7 \text{ cm}/\sqrt{E}$$

μCounter

8- 9 layers RPC

$$\delta R\Phi = 1.4 \text{ cm} \sim 1.7 \text{ cm}$$

η and η' events at BESIII

- 225 million J/ψ events taken in 2009
- ~ 1 billion J/ψ events taken in 2012
- η and η' production in J/ψ decays
 - $B(J/\psi \rightarrow \gamma\eta) \sim 1.1 \times 10^{-3} \rightarrow 2.3 \times 10^5$ η events
 - $B(J/\psi \rightarrow \gamma\eta') \sim 5.2 \times 10^{-3} \rightarrow 1.2 \times 10^6$ η' events
 - $B(J/\psi \rightarrow \phi\eta) \sim 7.5 \times 10^{-4} \rightarrow 1.7 \times 10^5$ η events
 - $B(J/\psi \rightarrow \phi\eta') \sim 4.0 \times 10^{-4} \rightarrow 0.9 \times 10^5$ η' events

The results in this talk are based on the data sample of 225M J/ψ events

Recent η and η' results from BESIII

- Matrix element for $\eta' \rightarrow \pi^+\pi^-\eta$
- Search for CP violation $\eta/\eta' \rightarrow \pi^+\pi^-, \pi^0\pi^0$
- BF measurement of $\eta' \rightarrow \pi^+\pi^-\pi^0, \pi^0\pi^0\pi^0$
- BF measurement of $\eta' \rightarrow \pi^+\pi^-e^+e^-, \pi^+\pi^-\mu^+\mu^-$
- Search for η/η' invisible decays
- Search for η/η' weak decays



Matrix Element for the Decay $\eta' \rightarrow \pi^+\pi^-\eta$

Phys. Rev. D83,012003(2011)

- Impact of gluon component on the dynamics of η' decays
- Comparison to the theoretical calculations with the effective ChPT
- Previous measurements on the dalitz plot of $\eta' \rightarrow \pi\pi\eta$ are from VES, GAMS and CLEO

$$X = \frac{\sqrt{3}}{Q}(T_{\pi^+} - T_{\pi^-}), \quad Y = \frac{m_\eta + 2m_\pi}{m_\pi} \frac{T_\eta}{Q} - 1.$$

$T_{\pi,\eta}$ denote the kinetic energies of mesons in the η' rest frame

$$Q = T_\eta + T_{\pi^+} + T_{\pi^-} = m_{\eta'} - m_\eta - 2m_\pi$$

Flat, seems no dynamics is involved

Two representations used

$$M^2 = A(1 + aY + bY^2 + cX + dX^2)$$

$$M^2 = A(|1 + \alpha Y|^2 + cX + dX^2)$$

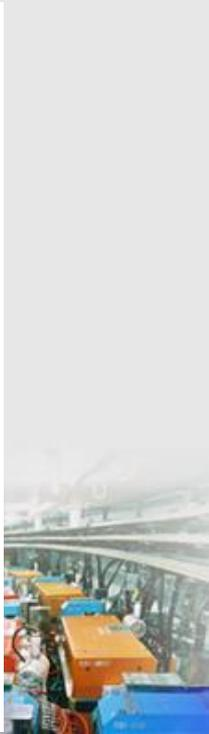
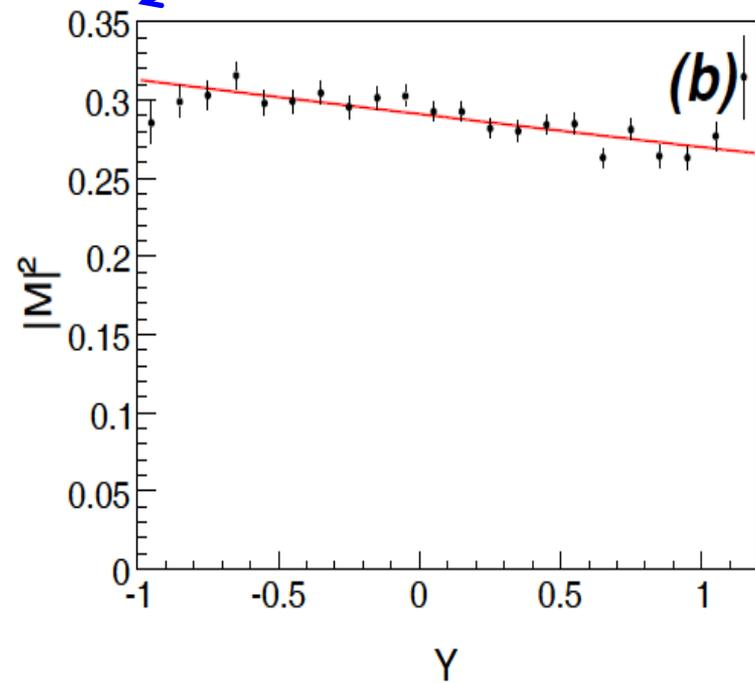
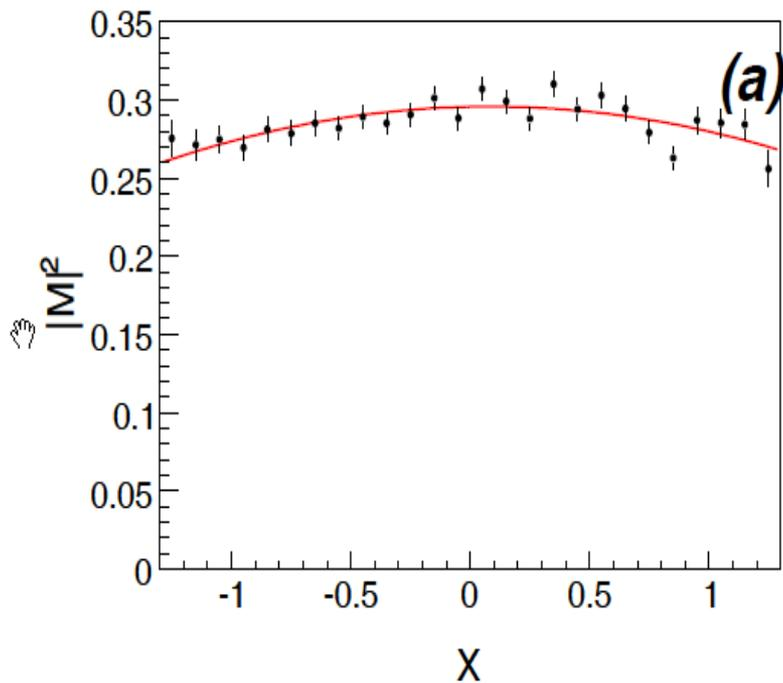
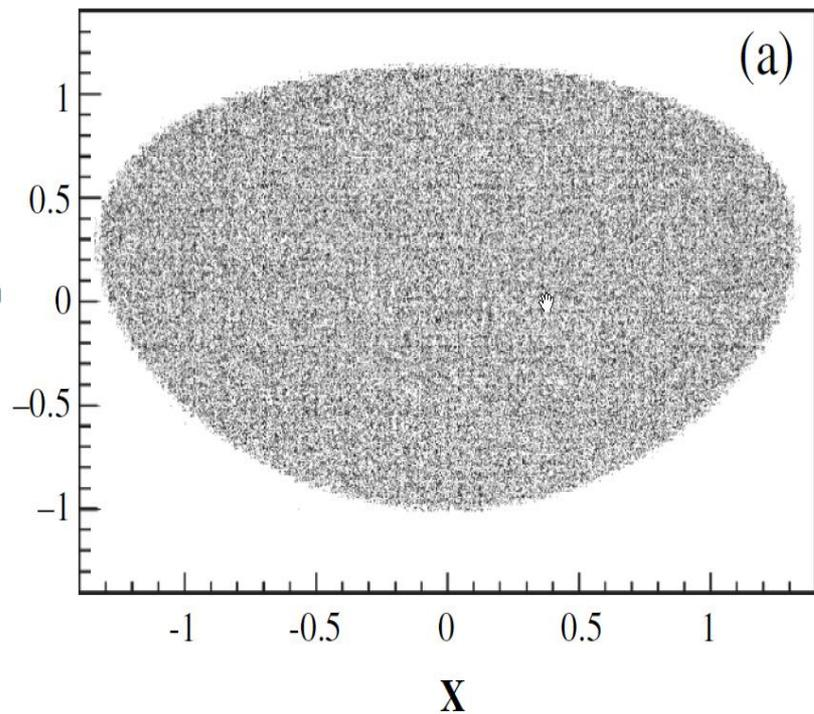

Results from the fit with two different representations

	Phys. Lett.B651,22(2007)	Eur. Phys.J.A26,383(2005)	
Parameter	VES [9]	Theory [26]	This work
a	-0.127 ± 0.018	-0.116 ± 0.011	-0.047 ± 0.012
b	-0.106 ± 0.032	-0.042 ± 0.034	-0.069 ± 0.021
c	$+0.015 \pm 0.018$	\dots	$+0.019 \pm 0.012$
d	-0.082 ± 0.019	$+0.010 \pm 0.019$	-0.073 ± 0.013

	Phys. Rev.Lett.84,26(2000)	Phys.At.Nucl.68,372(2005)	
Parameter	CLEO [11]	VES [27]	This work
$\text{Re}(\alpha)$	-0.021 ± 0.025	-0.072 ± 0.014	-0.033 ± 0.006
$\text{Im}(\alpha)$	0.000 (fixed)	0.000 ± 0.100	0.000 ± 0.050
c	0.000 (fixed)	$+0.020 \pm 0.019$	$+0.018 \pm 0.010$
d	0.000 (fixed)	-0.066 ± 0.034	-0.059 ± 0.013

- Part of parameters are not consistent with previous work
- “ c ”, defined for C parity violation, is consistent with zero within 2 standard deviations



Search for CP violation in $\eta/\eta' \rightarrow \pi\pi$

Phys. Rev. D84,032006(2011)

- Offer an excellent laboratory for testing P and CP invariance
- Theoretically proceed via the weak interaction at a level of $10^{-15} \sim 10^{-27}$

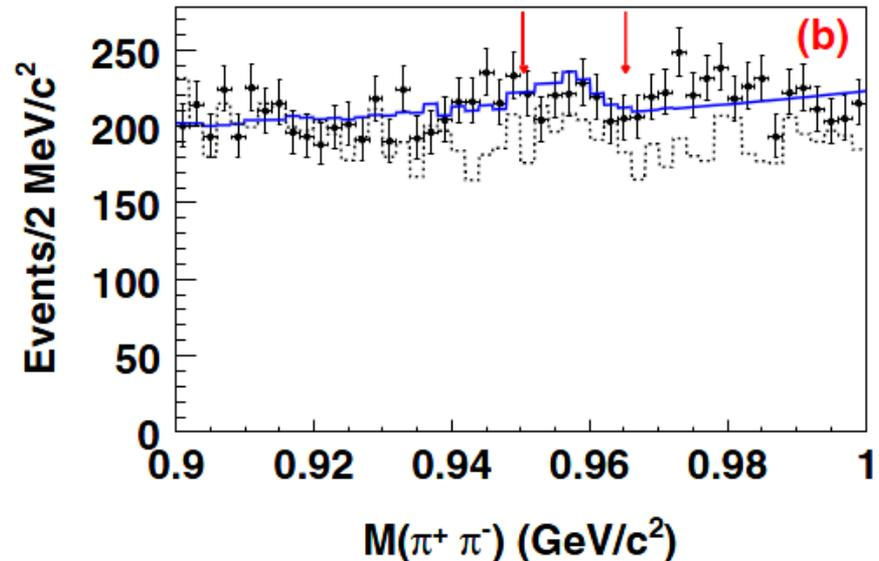
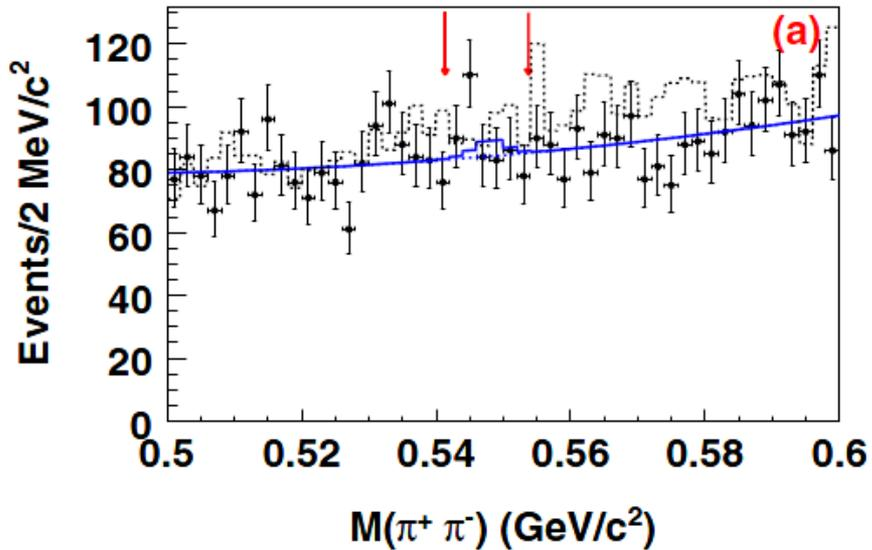

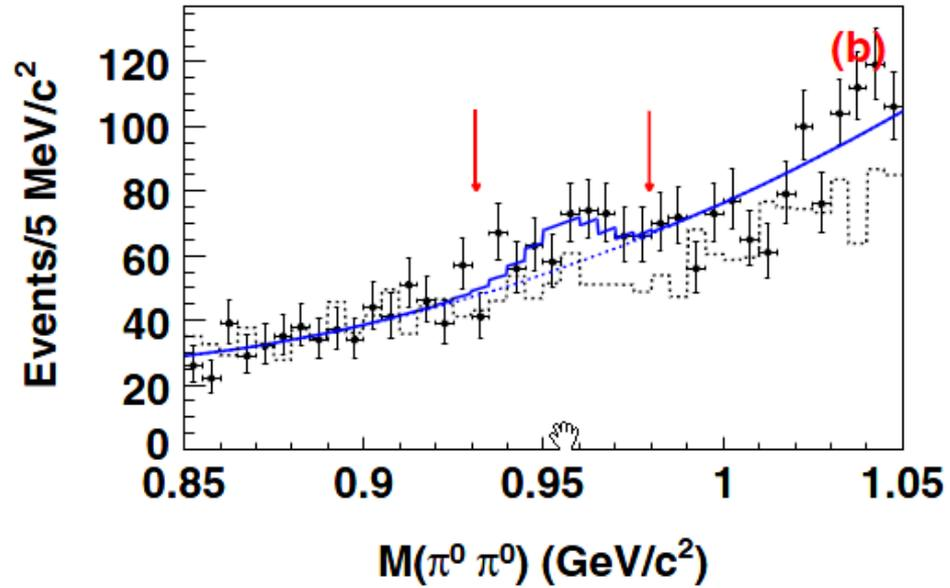
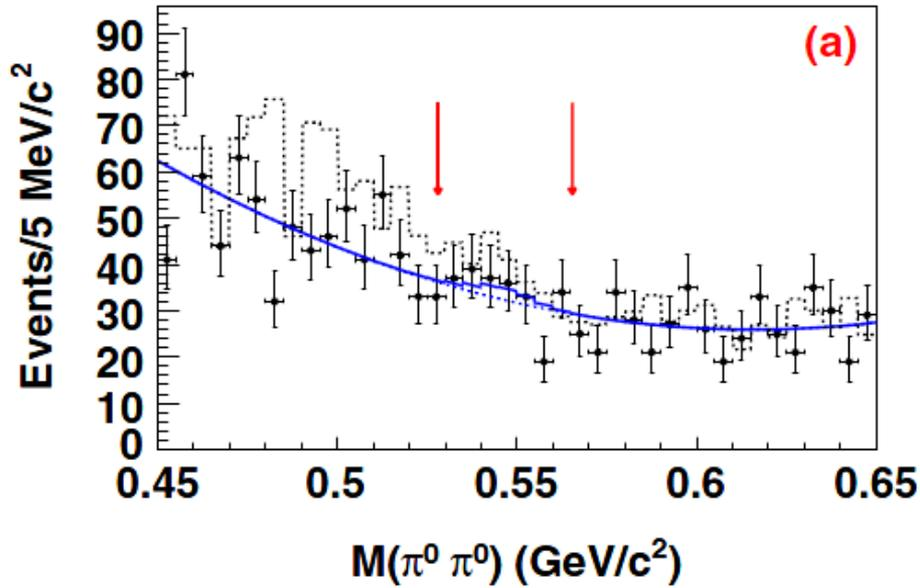

Process	\mathcal{B}^{UP}	$\mathcal{B}_{\text{PDG}}^{\text{UP}}$
$\eta \rightarrow \pi^+ \pi^-$	3.9×10^{-4}	1.3×10^{-5}
$\eta' \rightarrow \pi^+ \pi^-$	5.5×10^{-5}	2.9×10^{-3}
$\eta \rightarrow \pi^0 \pi^0$	6.9×10^{-4}	3.5×10^{-4}
$\eta' \rightarrow \pi^0 \pi^0$	4.5×10^{-4}	9×10^{-4}

@90% C.L.



BF measurement of $\eta' \rightarrow \pi^+\pi^-\pi^0, \pi^0\pi^0\pi^0$

- Isospin violating decay modes, related with the quarks
- Previous measurements are from GAM(S) and CLEOc

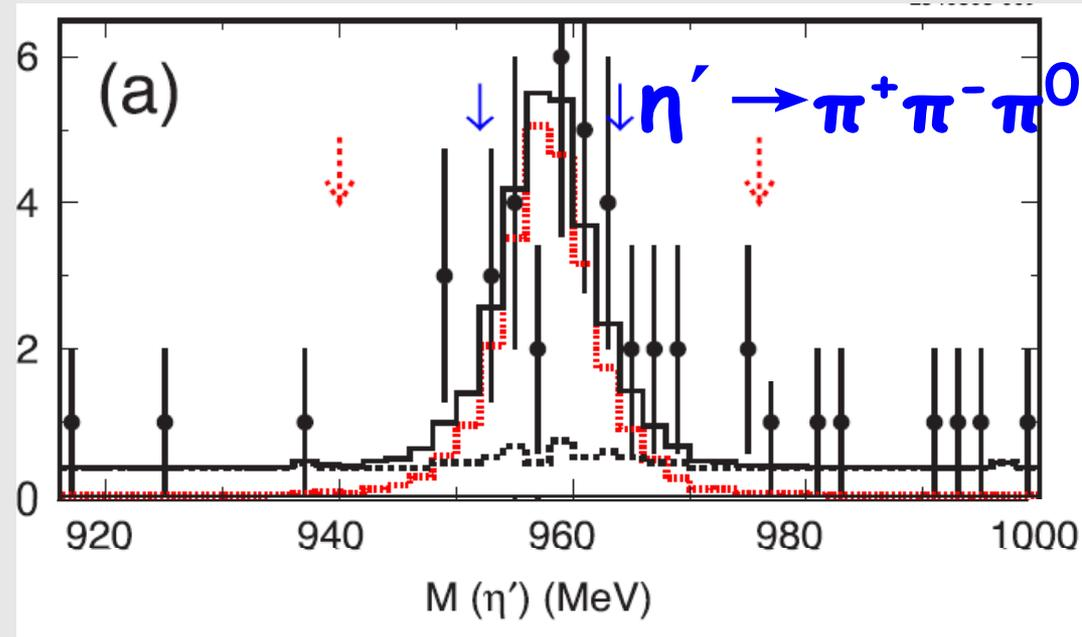
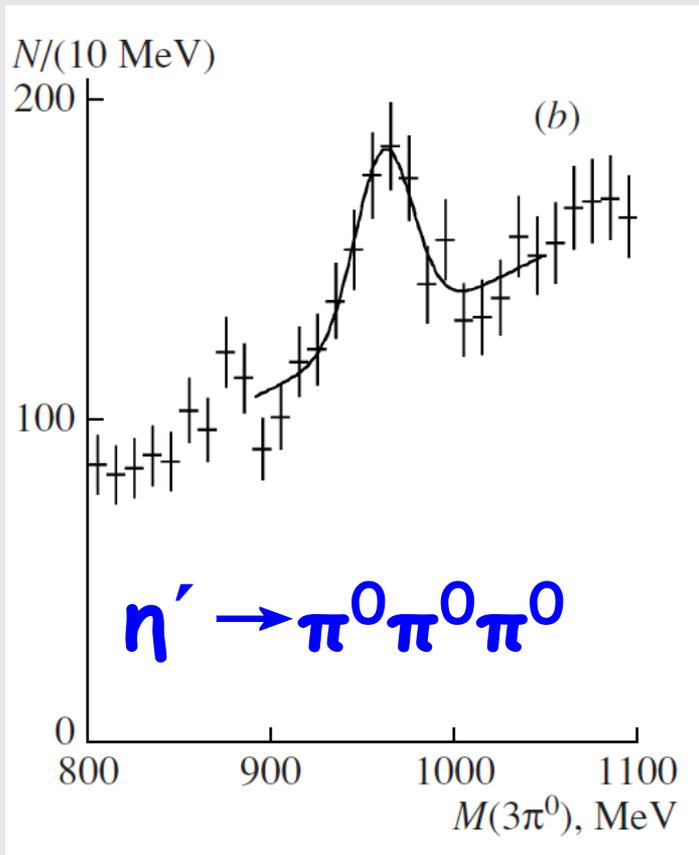

Phys. At.Nucl.71,2124(2008)

Phys. Rev.Lett.102,061801(2009)

BF measurement of $\eta' \rightarrow \pi^+\pi^-\pi^0, \pi^0\pi^0\pi^0$

PRL 108, 182001 (2012)

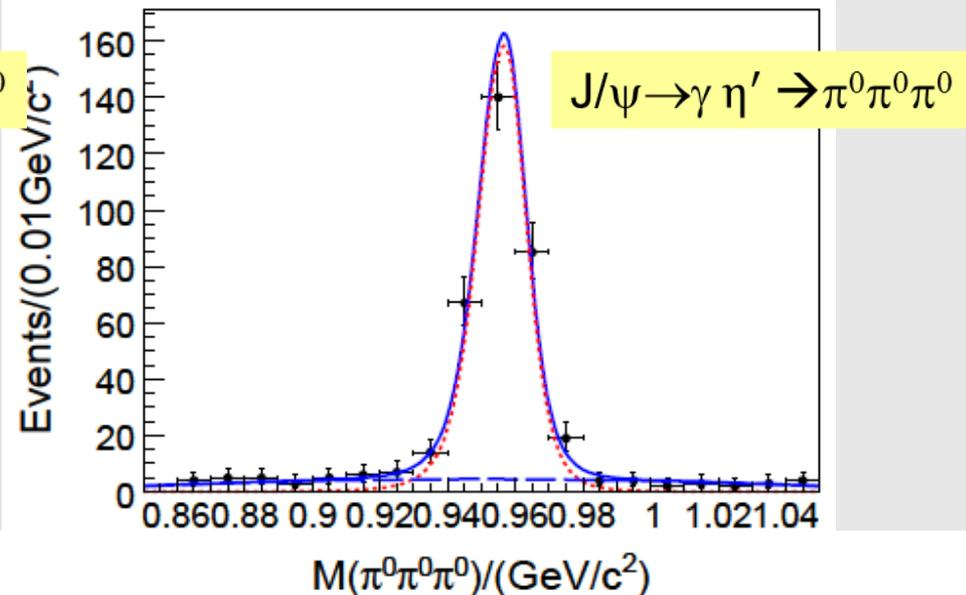
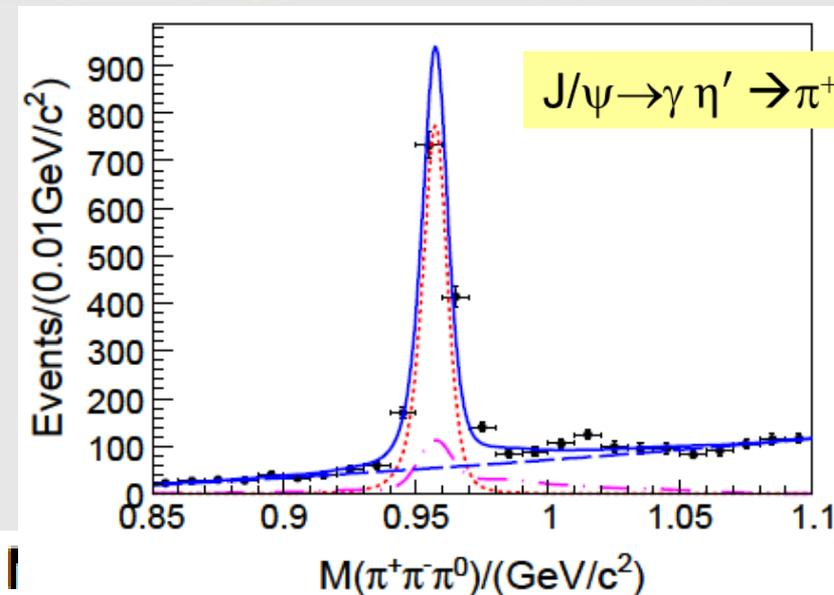

$$Br(\eta' \rightarrow \pi^+\pi^-\pi^0) = (3.83 \pm 0.15 \pm 0.39) \times 10^{-3} \quad \text{PDG12: } (3.6_{-0.9}^{+1.1}) \times 10^{-3}$$

$$Br(\eta' \rightarrow \pi^0\pi^0\pi^0) = (3.56 \pm 0.22 \pm 0.34) \times 10^{-3} \quad \text{PDG12: } (1.68 \pm 0.22) \times 10^{-3}$$

For the decay $\eta' \rightarrow \pi^0\pi^0\pi^0$, it is two times larger than the world average value.

Comparison: Isospin violations in $\eta' \rightarrow \pi\pi\pi$:

$$\frac{BR(\eta' \rightarrow \pi^+\pi^-\pi^0)}{BR(\eta' \rightarrow \pi^+\pi^-\eta)} \approx 0.9\%, \quad \frac{BR(\eta' \rightarrow \pi^0\pi^0\pi^0)}{BR(\eta' \rightarrow \pi^0\pi^0\eta)} \approx 1.6\%$$



BF measurement of $\eta' \rightarrow \pi^+\pi^-e^+e^-$, $\pi^+\pi^-\mu^+\mu^-$

● Theoretical predictions

Decay	Effective meson theory PRC 61,0305206(2000)	Chiral Unitary EPJA33,95(2007)
$B(\eta' \rightarrow \pi^+\pi^-e^+e^-)$	1.8×10^{-3}	$(2.13^{+0.19}_{-0.32}) \times 10^{-3}$
$B(\eta' \rightarrow \pi^+\pi^-\mu^+\mu^-)$	2.0×10^{-4}	$(1.57^{+0.96}_{-0.75}) \times 10^{-3}$

● $\eta' \rightarrow \pi^+\pi^-e^+e^-$ was first observed by CLEOc

$$B(\eta' \rightarrow \pi^+\pi^-e^+e^-) = (2.5^{+1.2}_{-0.9} \pm 0.5) \times 10^{-3}$$

$$B(\eta' \rightarrow \pi^+\pi^-\mu^+\mu^-) < 2.4 \times 10^{-4} \quad @90\%C.L.$$

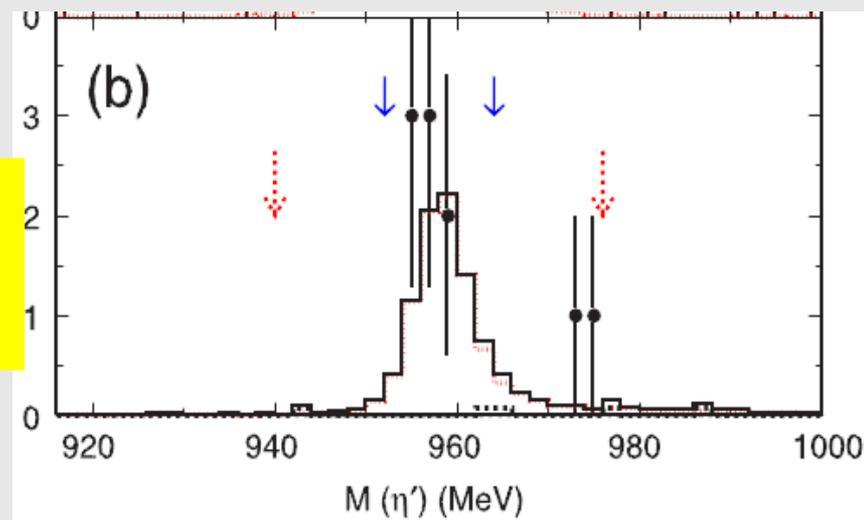

Phys. Rev.Lett.102,061801(2009)

Measurements of $\eta' \rightarrow \pi^+ \pi^- l^+ l^-$

Phys. Rev. D87, 092011 (2013)

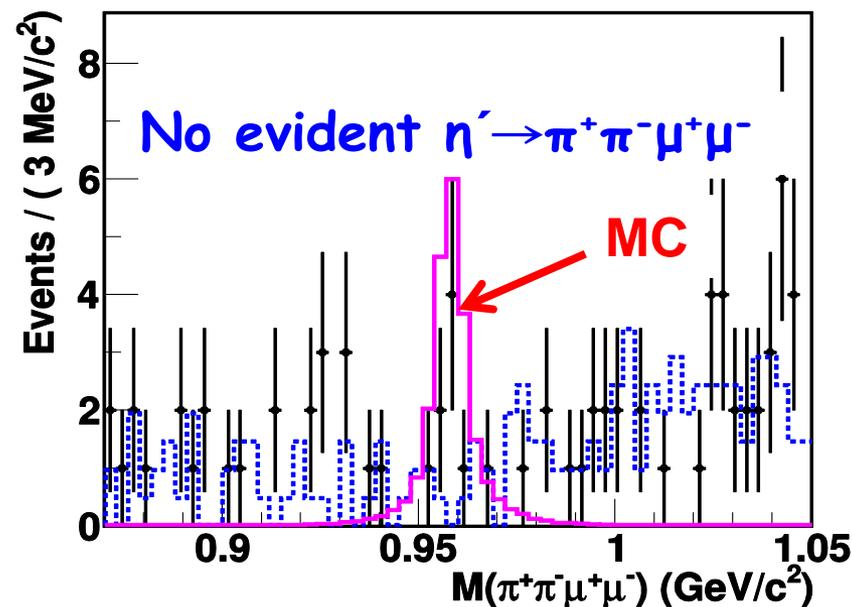
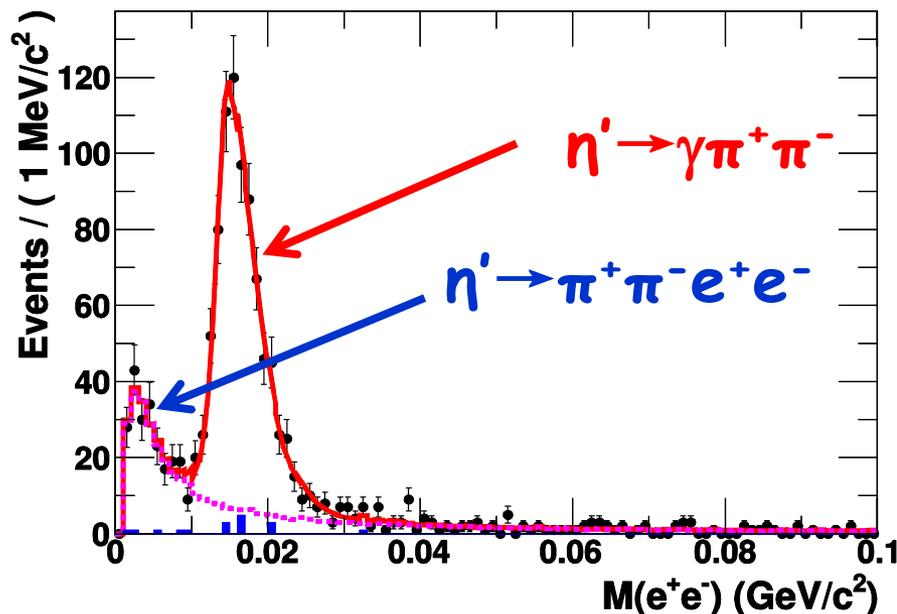

$$B(\eta' \rightarrow \pi^+ \pi^- e^+ e^-) = (2.11 \pm 0.12 \pm 0.15) \times 10^{-3}$$

$$B(\eta' \rightarrow \pi^+ \pi^- \mu^+ \mu^-) < 2.9 \times 10^{-5} \text{ @90\%C.L.}$$

$$B(\eta' \rightarrow \pi^+ \pi^- e^+ e^-) = (2.5^{+1.2}_{-0.9} \pm 0.5) \times 10^{-3} \quad (\text{CLEOC})$$

$$B(\eta' \rightarrow \pi^+ \pi^- \mu^+ \mu^-) < 2.4 \times 10^{-4} \text{ @90\%C.L.} \quad (\text{CLEOC})$$

Search for $\eta/\eta' \rightarrow$ invisible in $J/\psi \rightarrow \phi \eta/\eta'$

- offer a window for physics beyond the standard model
- observation of the invisible final states (may) provides information of light dark matter
- easy to tag with $J/\psi \rightarrow \phi \eta/\eta'$: two body decays: ϕ 's width is quite narrow

Theoretical predictions:

B. McElrath PRD 72, 103508(2005)

$$B(\eta \rightarrow \chi\chi) \sim 7.4 \times 10^{-5}$$

$$B(\eta' \rightarrow \chi\chi) \sim 8.1 \times 10^{-7}$$

$$B(\eta' \rightarrow \text{invisible}) < 1.4 \times 10^{-3}$$

$$B(\eta \rightarrow \text{invisible}) < 6.0 \times 10^{-4}$$

@ 90% C.L.

BESII result: PRL 97, 202002 (2006)

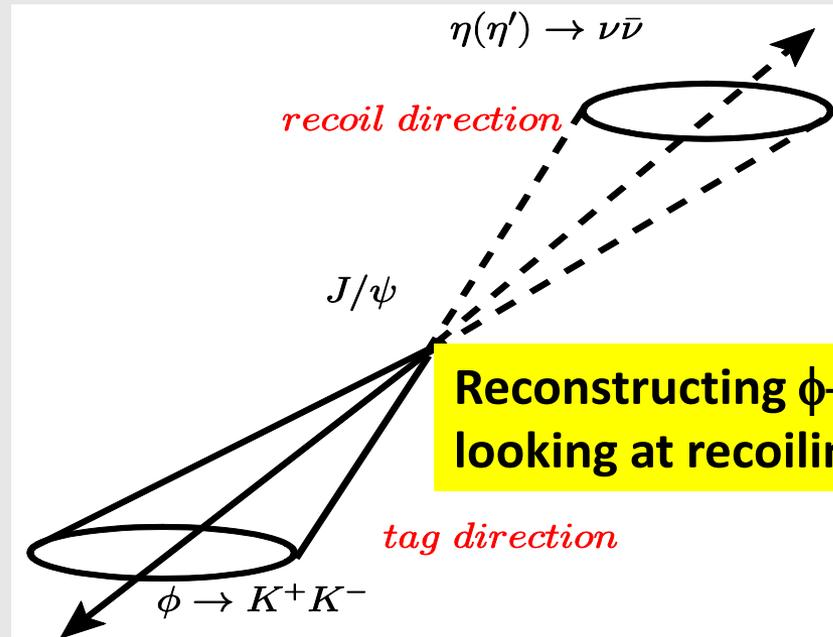

Search for $\eta/\eta' \rightarrow$ invisible in $J/\psi \rightarrow \phi\eta/\eta'$

Phys. Rev. D87, 032006 (2013)

$$B(\eta \rightarrow \text{invisible})/B(\eta \rightarrow \gamma\gamma) < 2.6 \times 10^{-4}$$

$$B(\eta' \rightarrow \text{invisible})/B(\eta' \rightarrow \gamma\gamma) < 2.4 \times 10^{-2}$$

@90%C.L.

Many uncertainty related to tag side and Detector noise cancelled in the ratio

$$B(\eta \rightarrow \text{invisible}) < 1.0 \times 10^{-4}$$

$$B(\eta' \rightarrow \text{invisible}) < 5.3 \times 10^{-4}$$

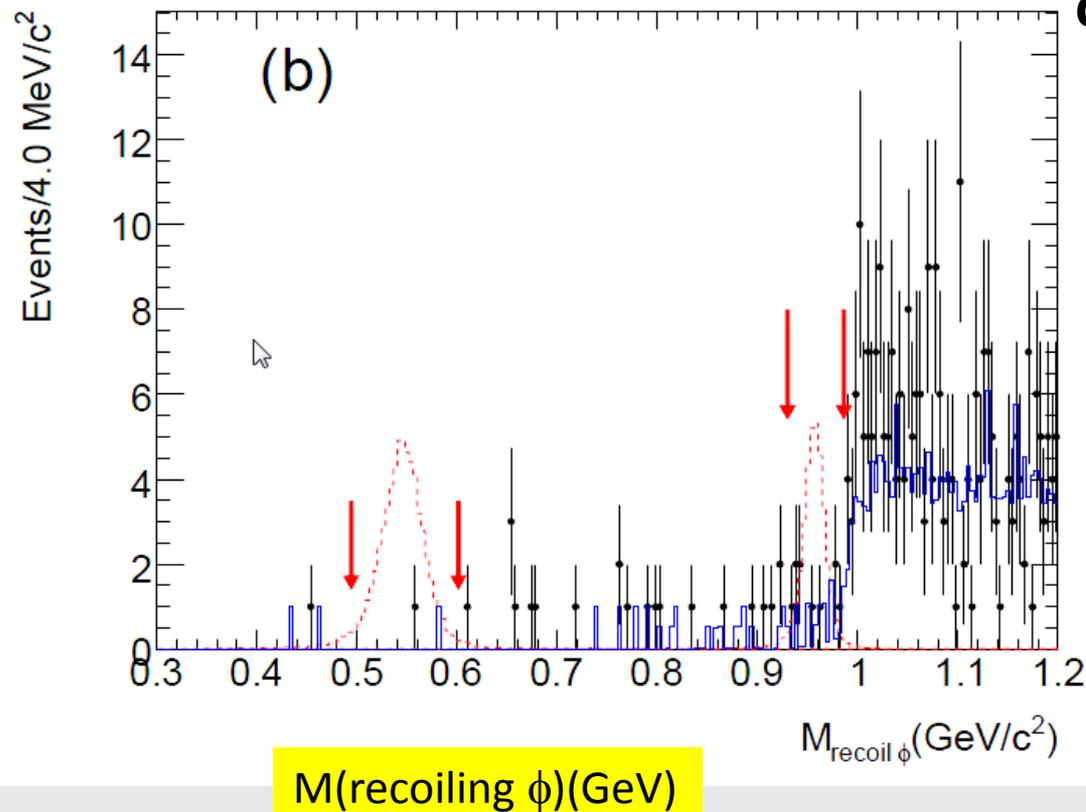

Theory:

B. McElrath PRD 72, 103508(2005)

$$\text{BR}(\eta \rightarrow \chi\chi) \sim 7.4 \times 10^{-5}$$

$$\text{BR}(\eta' \rightarrow \chi\chi) \sim 8.1 \times 10^{-7}$$



Search for weak decays of η/η'

Phys. Rev. D87, 032006 (2013)

- within SM : $B(\eta \rightarrow \pi^- e^+ \nu + c.c.) \sim 2 \times 10^{-13}$

H. Neufeld and H. Rupertsberger, Z. Phys. C 68, 91 (1995)

- by considering scalar or vector type interactions:

$B(\eta \rightarrow \pi^- e^+ \nu + c.c.) \sim 10^{-8} - 10^{-9}$ P. Herczeg, Prog. Part. Nucl. Phys. 46, 413 (2001)

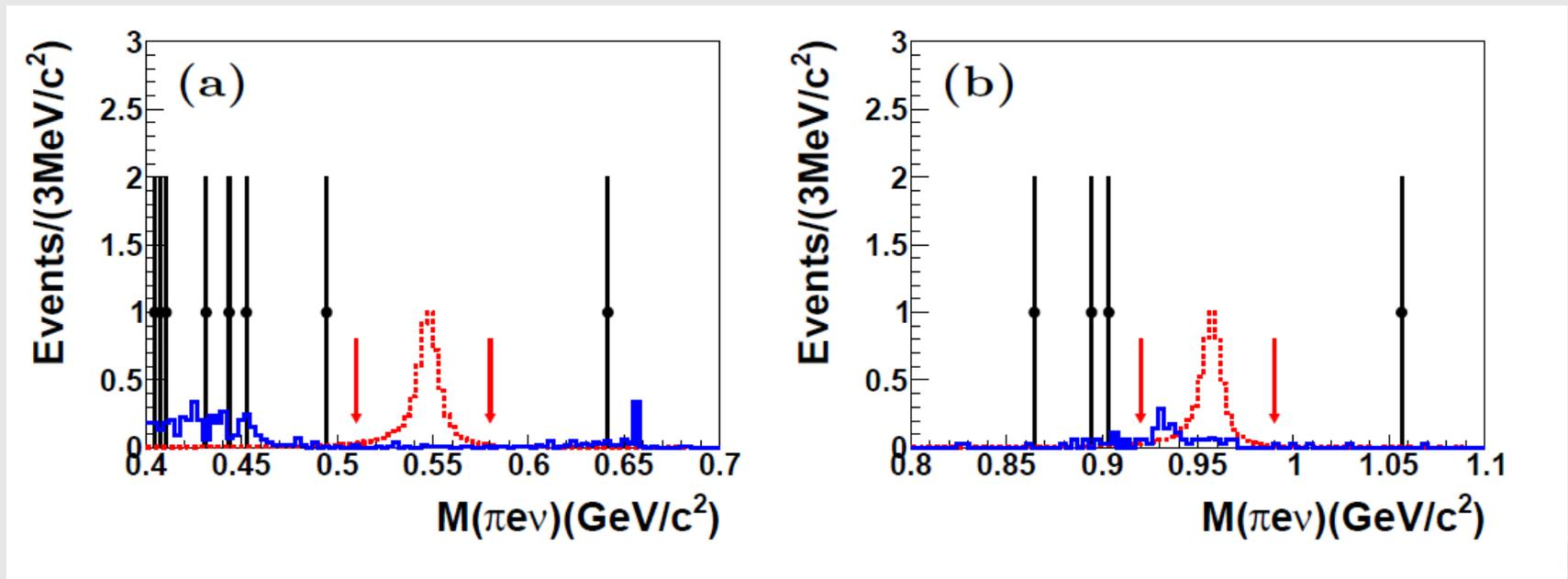

$B(\eta \rightarrow \pi^- e^+ \nu + c.c.) < 1.7 \times 10^{-4}$
 $B(\eta' \rightarrow \pi^- e^+ \nu + c.c.) < 2.2 \times 10^{-4}$ @90% C.L.



Summary & Perspective

- η/η' decays: a rich physics field
- Recent results from BESIII are presented
 - $\eta' \rightarrow \pi^+\pi^-\eta$,
 - $\eta (\eta') \rightarrow \pi^+\pi^-, \pi^0\pi^0$,
 - $\eta' \rightarrow \pi^+\pi^-\pi^0, \pi^0\pi^0\pi^0$
 - $\eta' \rightarrow \pi^+\pi^-l^+l^-$
 - invisible & weak decays
- ~1 billion J/ψ events were taken last year



Summary & Perspective

- plan to update the study of η' decays
 - Study dynamics of $\eta/\eta' \rightarrow \gamma\pi^+\pi^-$
 - Dalitz plot of $\eta' \rightarrow \pi^+\pi^-\eta$,
 - Dalitz plot of $\eta/\eta' \rightarrow \pi^+\pi^-\pi^0, \pi^0\pi^0\pi^0$
 - Search for η' new decay modes ($4\pi, \gamma\gamma\pi^0 \dots$)
 - Test of C, P or CP violations
 -
- η decays: complementary to other experiments
- more results are expected to come soon !



Thanks for you attention

